

# Installation, Maintenance and User Instructions

# Zip InLine

## Electronically Controlled Instantaneous Water Heaters

## Models CEX-O & CEX-U

Issued August 2011



Zip Heaters (UK) Ltd  
 14 Bertie Ward Way  
 Dereham  
 Norfolk  
 NR19 1TE

Telephone 0845 6024533  
 Facsimile 01362 692448  
[www.zipheaters.co.uk](http://www.zipheaters.co.uk)



The terms 'Zip' and 'InLine' are registered trademarks.

9120 - 2546

Please read these instructions carefully **before** commencing installation of the InLine water heater.  
 Please leave these instructions with the end user after installation.

## Contents

<b>Description</b>	2
<b>Approvals</b>	2
<b>Warnings</b>	3
<b>Technical data</b>	4
<b>Dimensions</b>	5
<b>Spare parts</b>	6
<b>Installation</b>	
Requirements	7
Installation site	7
Installing the appliance	8
Electrical connection	9
<b>Commissioning</b>	10
<b>Service menu</b>	12
<b>Operation</b>	14
<b>Cleaning and maintenance</b>	17
<b>Fault finding</b>	17
<b>Warranty</b>	18

The use of this crossed out wheeled bin logo indicates that this product needs to be disposed of separately to any other household waste.

Within each of the European Union member countries, provisions have been made for the collection and recycling of unwanted electrical and electronic equipment.

In order to preserve our environment we ask that you dispose of this product correctly. Please contact Zip Customer Service for advice on 0845 602 4533.



## Warranty

The Zip appliance you have chosen is precision-built from the finest materials available and should give many years of trouble free service.

Certain warranties may be implied by law into your contract with Zip. The warranty provided below is additional to these implied warranties and nothing set out below shall limit your statutory rights or rights at law.

Zip Heaters (UK) Ltd warrants that, should any part fail within 12 calendar months of installation, that part will be repaired or replaced free of charge by Zip or its Distributor or Service Provider, except as set out below, provided the appliance is installed and used strictly in accordance with the instructions supplied, and that failure is not due to accident, misuse, abuse, unsuitable water conditions, or to any alteration, modification or repair by any party not expressly nominated by Zip.

No costs are payable by the customer other than any mileage or travelling-time charges incurred by a Zip Service Provider or the cost of removal, cartage and re-installation of any component of the appliance if it needs to be returned for repair to Zip or its Distributor.

This warranty does not cover damage resulting from non-operation of the appliance or consequential damage to any other goods, furnishings or property.

Zip does not exclude, restrict or modify any liability that cannot be excluded, restricted or modified or which cannot, except to a limited extent, be excluded, restricted or modified as between the owner or user and Zip under the laws applicable.

Furthermore, this warranty does not displace any statutory warranty, but, to the extent to which Zip is entitled to do so, the liability of Zip under any statutory warranty will be limited at Zip's option to the replacement of the appliance or supply of equivalent appliance, the payment of the cost of replacing the appliance or acquiring an equivalent appliance, or the payment of the cost of having the appliance repaired or the repair of the appliance.

## **Description**

Zip InLine CEX-O and CEX-U instantaneous water heaters are micro-processor controlled, pressure resistant water heaters suitable for supplying hot water to one or more outlets.

The heating element switches on automatically when the hot water tap is opened and switches off automatically when the hot water tap is closed.

The electronic control system automatically regulates the power consumption depending on the supply water temperature and flow rate to achieve the required outlet temperature within the power limit of the appliance.

Power consumption is also regulated based on outlet temperature to ensure the required temperature is achieved exactly to the degree and irrespective of fluctuations in voltage and water pressure.

The power rating of the appliance can be selected as either 9.6kW or 7.2kW at 240V at the time of installation.

The required outlet temperature can be entered on a keypad within the range 30°C to 55°C and can be read off the digital display.

The maximum inlet temperature of 70°C is suitable for use with preheated water e.g. from solar heating systems.

## **Approvals**

Zip InLine CEX-O and CEX-U are VDE approved to the LVD and EMC directives and are CE endorsed.

Zip InLine CEX-O and CEX-U have been examined, tested and found when correctly fitted to comply with the requirements of the United Kingdom Water Regulations / Byelaws (Scotland). The products are listed under the WRAS (Water Regulations Advisory Scheme) Water Fittings and Materials Directory.

## Warnings

- Installation, commissioning and maintenance of this appliance must only be carried out by a competent installer who will then be responsible for adhering to all relevant standards and regulations.
- The appliance must only be used when correctly installed and in perfect working order!
- The appliance must be installed in a frost-free room! The appliance must never be exposed to frost.
- The appliance must be earthed at all times!
- The appliance must only be used for heating potable water. The specific water resistance must not fall below the required value indicated on the rating plate. The appliance must not be used for any other purpose.
- The maximum water pressure must not exceed the value indicated on the rating plate.
- The incoming water temperature must not exceed 70°C.
- Before commissioning for the first time and each time the appliance is emptied (e.g. due to work on the plumbing system, if there is a risk of freezing or in case of maintenance), the appliance must be vented by opening and closing the hot water tap until all air has been eliminated from the water heater and no more air emerges before re-connecting to the electrical supply.
- The front cover of the appliance must never be opened before disconnecting the appliance from the mains power supply!
- The appliance and its wiring and piping must not be modified in any way!
- Be careful! Temperatures in excess of approx. 43°C are perceived as hot, especially by children, and may cause a feeling of burning. When the appliance has been in use for some time, the fittings may be very hot!
- In case of malfunction isolate the power supply immediately. In case of leaks also isolate the water supply. Repairs must only be carried out by Zip Heaters (UK) Ltd or an authorized Zip service engineer.
- This appliance must not be used by any person (including children) with limited physical, sensory or mental abilities or lacking suitable experience and/or knowledge unless they are supervised by a person responsible for their safety or have received instructions about how to use the appliance. Children should be supervised in order to make sure that they do not play with the appliance.
- Zip Heaters (UK) Ltd cannot be held liable for any damages caused by failure to observe these instructions.

## Technical data

Model	CEX-O	CEX-U
Application	Over-sink	Under-sink
Power rating	7.2kW / 9.6kW <sup>(1)</sup>	
Rated current	<b>30A</b> (7.2kW) / <b>40A</b> (9.6kW)	
Power supply	1/N/PE~240V AC	
Hot water (l/min) Maximum at $\Delta t = 25K$	4.1 (7.2kW) / 5.0 <sup>(2)</sup> (9.6kW)	
Rated volume (litres)	0.3	
Rated pressure	1 MPa (10 bar)	
Element type	Bare wire heating system IES	
Required specific water resistance	>1100 $\Omega$ cm @ 15°C	
Maximum inlet temperature	70°C	
Switch on flow rate (l/min)	2.0	
Maximum flow rate (l/min)	5.0 <sup>(2)</sup>	
Pressure loss @ 2.5 l/min @ 9.0 l/min	0.2 bar 1.3 bar <sup>(3)</sup>	
Temperature setting range	30°C – 55°C	
Maximum weight (kg)	2.70	
Dimensions H x W x D (mm)	294 x 177 x 108	
Water connections	½" BSP	
Protection class	IP25	IP24

<sup>(1)</sup> Power rating selected at time of installation

<sup>(2)</sup> Flow rate limited to achieve optimum temperature rise

<sup>(3)</sup> Without flow regulator

- Minimum flow rate 2.0 litres/minute.
- A minimum water pressure of 2 bar is recommended for optimum performance.
- Maximum flow rate will be achieved at a water pressure of 6 bar.

# Dimensions

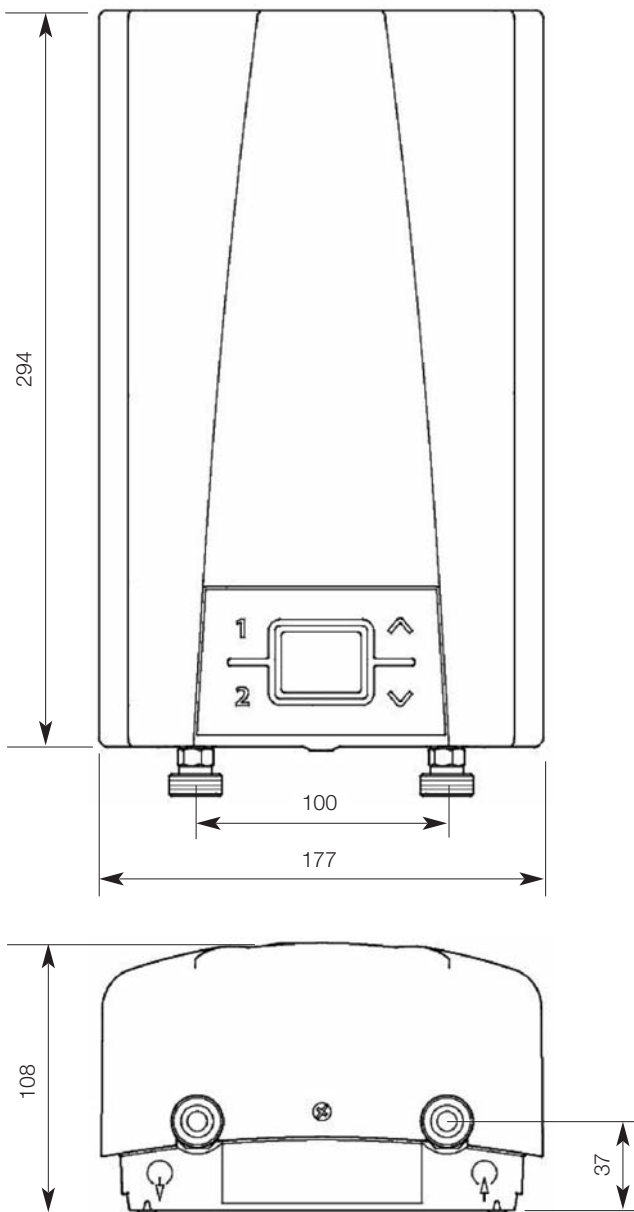

## Spare parts

When ordering spare parts, please always specify the appliance model and serial number.

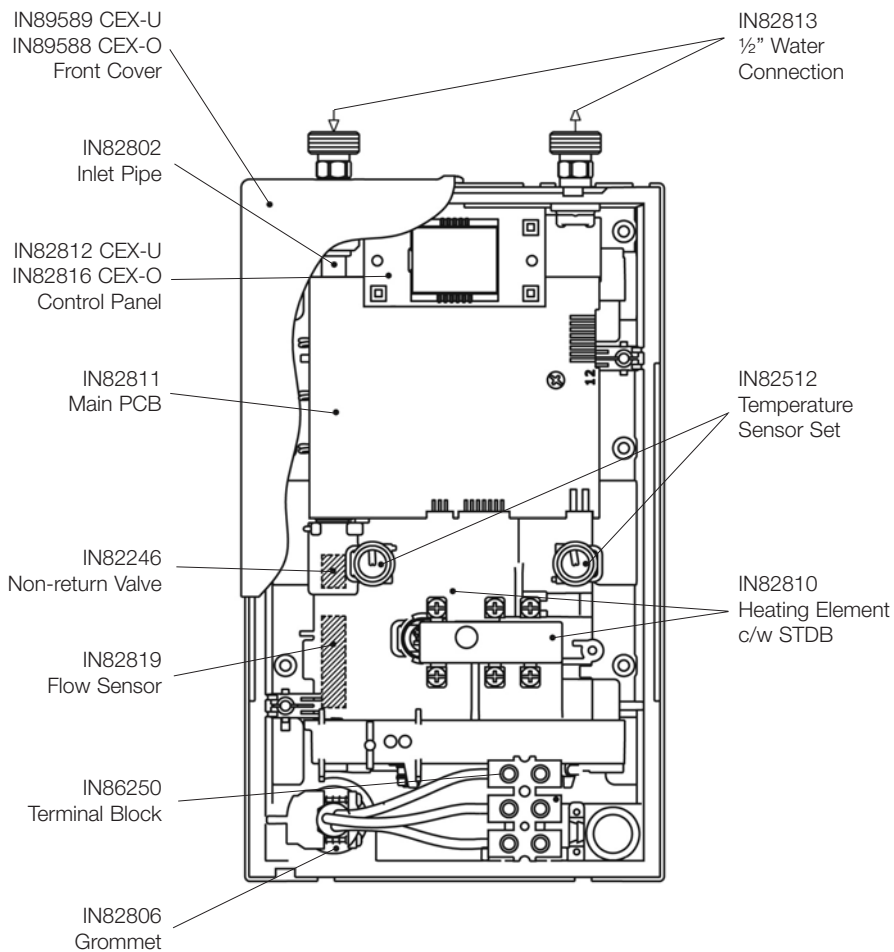

# Installation

## Requirements

- These instructions must be read and fully understood before commencing the installation. If in doubt, or in need of further guidance please ring Zip on 0845 602 4533.
- Zip InLine water heaters must be installed by a competent person familiar with electric instantaneous water heaters.
- Installations must comply fully with UK Water Regulations and any Local Authority requirements.
- The electrical installation including earthing and cross bonding should comply with current IEE regulations and any Local Authority requirements.
- Zip InLine water heaters must be installed according to the specification on the rating plate and the technical specifications.
- The appliance must be permanently connected to the electrical supply through an isolation switch having a contact separation of at least 3mm on all poles.
- To protect the appliance, a circuit breaker must be fitted with a rating suitable for the nominal current of the appliance.
- The cross sectional area of the connection cable must be in accordance with the power rating of the appliance and the specific requirements of the installation site up to a maximum cable size of 10mm<sup>2</sup>.
- Take care to protect the wiring from damage during installation and ensure that the wiring is not directly accessible after installation.
- Check that the power supply is switched off prior to electrical connection.
- **This appliance must be earthed.**

## Installation site

- The installation site must be free from frost at all times.
- The appliance is designed for wall mounted installation. CEX-O for over-sink installation must be installed with the water connections downward. CEX-U for under-sink installation must be installed with the water connections upward.
- The appliance complies with protection class IP25 for over-sink installation, protection class IP24 for under-sink installation and may therefore be installed in protection zone 1.
- In order to minimise thermal losses, the distance between the appliance and the outlet fitting should be as short as possible. Recommended maximum distance 2 metres.
- For maintenance work a shut off valve should be installed in the water supply line to the heater.
- Hot and cold water connecting pipes should be WRAS approved and of copper or steel construction. Plastic pipes may only be used if conforming to DIN 16893 Series 2. The hot water pipes must be thermally insulated.
- The specific resistance of the supply water must be at least 1,100  $\Omega$ cm at 15°C. The specific resistance can be checked with the local water supply company.



## Installing the appliance

1. Thoroughly flush the water supply pipes before installation to remove any water borne debris.
2. Hold the appliance on the wall and mark the drill lines at top and bottom, left and right, corresponding to the small notches at the edge of the front cover (see Fig 1).
3. Join the top and bottom marks vertically (A-A) and the left and right marks horizontally (B-B). The intersections of these lines are the drill points (see Fig 2).
4. Drill the holes using a 6mm drill then insert the dowels and screws provided leaving the screws protruding 5mm from the wall.
5. Hang the appliance with the screws engaging in the key-hole slots in the back plate until it clicks into place (see Fig 3).
6. Attach the water connecting pipes to the appliance water connections using the 1/2" seals.
7. Ensure that all air is eliminated from the water heater by opening and closing the hot water tap until all air has been eliminated from the water heater and no more air emerges.

Fig 1

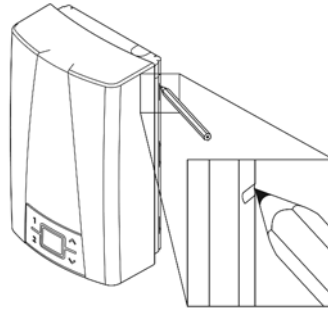

Fig 2

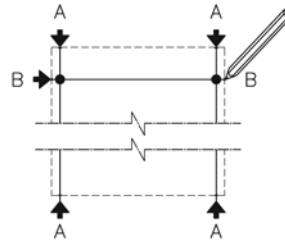
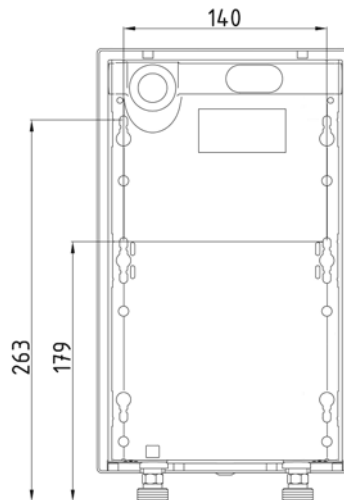

Fig 3



## Electrical connection

The electrical installation including earthing and cross bonding should comply with current IEE regulations and any Local Authority requirements.

The appliance must be installed according to the specification on the rating plate and the technical specifications.

### The appliance must be earthed.

The appliance must be permanently connected to the electrical supply through an isolation switch having a contact separation of at least 3mm on all poles.

The cross sectional area of the connection cable must be in accordance with the power rating of the appliance and the specific requirements of the installation site up to a maximum cable size of 10mm<sup>2</sup>.

Take care to protect the wiring from damage during installation and ensure that any uninsulated wiring is not directly accessible after installation.

To protect the appliance, a circuit breaker must be fitted with a rating suitable for the nominal current of the appliance.

### Check that the power supply is switched off prior to electrical connection!

1. With the appliance cover removed insert the power cable through the water splash protection grommet in the backplate. The splash protection grommet must be used and free from damage.
2. Remove inner and outer insulation from the connecting cable to the lengths shown in Fig 4.
3. Secure the cable using the cord grip. The cord grip must be used.
4. Fit the connecting cables into the terminal block according to the wiring diagram above. Ensure all connections are fully tightened and secure.
5. Re-fit the appliance cover taking care not to trap the cable from the display panel and secure the cover with the fixing screw (see Fig 5).

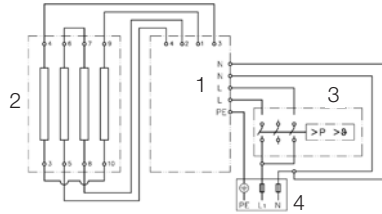

### Wiring Diagram

1. Circuit board
2. Heating element
3. Safety pressure switch and safety thermal cut-out
4. Terminal block

Fig 4

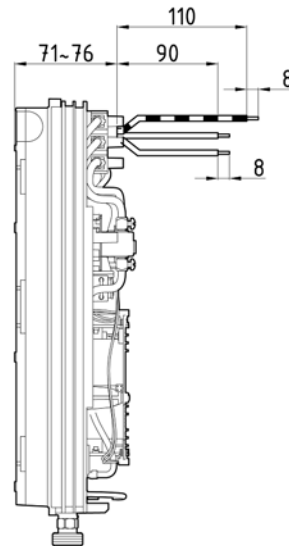
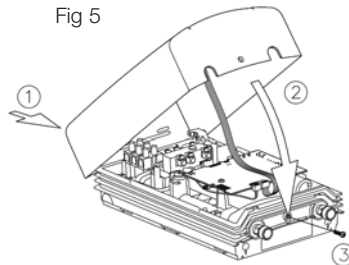

Fig 5



## Commissioning

Before switching on the power supply, ensure the appliance is completely filled with water by carefully opening and closing the hot water tap until all air has been eliminated from the water heater and no more air emerges.

Each time the appliance is drained (e.g. after work on the plumbing system or following repairs to the appliance), the heater must be re-vented in this way before reconnecting the power supply.

If the appliance does not operate after connecting the power supply check that the safety thermal cut-out (STDB) did not trip during transportation. To do this open the cover and, if necessary, re-set the STDB by pushing the switch in (see Fig 6).

### Note: Power Rating Selection

The maximum power rating of the appliance can be selected as either 9.6kW or 7.2kW at the time of installation. The unit will only commence normal operation after selection of the power rating. The maximum power rating should only be selected with reference to the technical data on page 4, after ensuring that correct cable sizing and fuse protection is in place and with regard to local site conditions and electrical regulations.

### This should only be done by a competent installer.

1. Switch on the power supply to the appliance. The digital display will light up.
2. When switching on power for the first time "88" will flash on the display (see Fig 7). If not, please refer to the section below "Reinstallation".
3. Use the arrow up and arrow down keys to select the required maximum power rating. Display "88" for 8.8kW at 230V (9.6kW at 240V) or display "66" for 6.6kW at 230V (7.2kW at 240V).
4. Press program key 1 to confirm the selection after which the appliance will start to operate.
5. Mark the set power rating on the product rating plate.
6. After selecting the maximum power rating, the heating element will activate after approximately 10 seconds of continuous water flow.
7. Open the hot water tap and check the appliance is functioning correctly.
8. Explain operation of the appliance to the end user and leave the operating instructions for their reference.
9. Complete the product registration card and return it to Zip Heaters or register the product on line at [www.zipheaters.co.uk](http://www.zipheaters.co.uk)

Fig 6

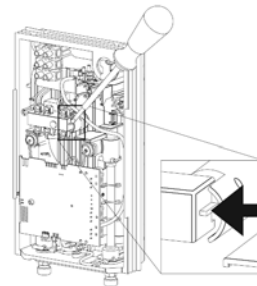

### Multiple Power System:

The maximum power rating is 9.6kW and can be changed to 7.2kW during installation.

Fig 7

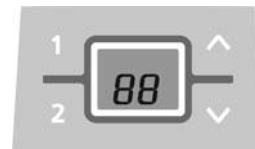

## Reinstallation

If the appliance is to be re-commissioned under different installation conditions it may be necessary to alter the maximum power rating.

**This should only be done by a competent installer.**

To re-set the maximum power rating use a screwdriver to short circuit the two pins as shown in Fig 8.

This will reset all heater parameters to factory settings.

Value "88" will flash in the display panel until the maximum power rating has been selected.

Fig 8

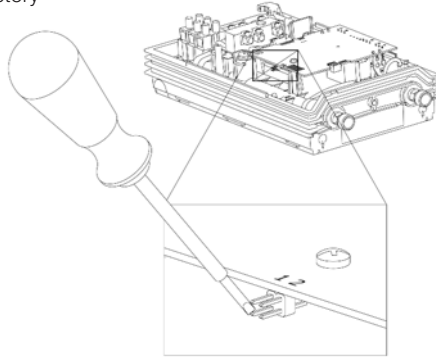

## Lock level

Operation of the appliance can be restricted. Refer to instructions under "Service Menu" to set the lock level.

**This should only be done by a competent installer.**

### Activation of the Lock level:

1. Set the required lock level in the service menu (refer to instructions under "Service Menu").
2. Disconnect the power supply to the unit.
3. Move the jumper on the main PCB from pin 2 to pin 1 (see Fig 9).
4. Reconnect the power supply to the unit.

### Deactivation of the Lock level:

1. Disconnect the power supply to the unit.
2. Move the jumper on the main PCB from pin 1 to pin 2.
3. Reconnect the power supply to the unit.

Fig 9

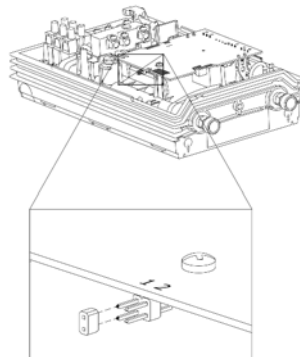

## Service menu

The service menu can be used for diagnostics and to view and configure appliance settings.

Press program keys 1 and 2 simultaneously for at least 2 seconds to enter the service menu confirmed by the display “FL” and flashing point (see Fig 10).

Scroll between menu items in the service menu using the arrow up and arrow down keys.

Press program key 1 to display the value of the currently selected menu item. The value flashes in the display.

The values of some menu items can be displayed by using the arrow up and arrow down keys.

Press program key 1 to return to the menu item list.

Press program key 2 to exit the service menu and return to the standard display.

After two minutes without any key stroke the system automatically returns to the standard display.

Fig 10

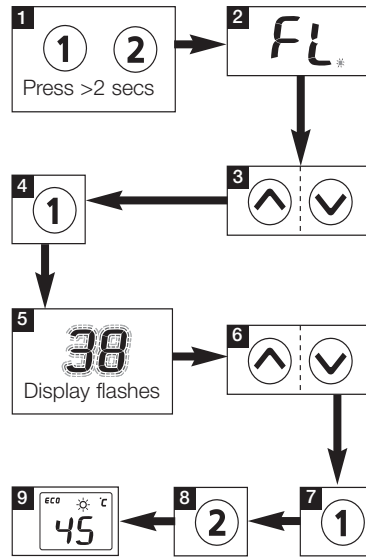

### Menu item order of Service Menu:

↑	<b>FL</b> Flow:	Flow rate (l/min)
↑	<b>PO</b> Power:	Power consumption (kW)
↑	<b>t1</b> Temp in:	Inlet temperature (°C)
↑	<b>t2</b> Temp out:	Outlet temperature (°C)
↑	<b>[R]</b> Control value:	Calibration value of the control system (40 - 60)
↑	<b>PL</b> Power limit:	Maximum power setting (kW)
↑	<b>Er</b> Diagnostics:	Last ten diagnostic messages (see below)
↑	<b>LL</b> Lock level:	Current lock level setting (see below)
↑	<b>nr</b> Software version:	Installed software version
↑	<b>[h</b> Radio channel:	Radio channel of heater and remote control
↑	<b>rS</b> Received strength:	Signal quality of remote control (10% - 100%)
↑	<b>!E</b> Signal:	Quality of radio contact with diagnostic display

### **“Er”: Diagnostics**

The last ten diagnostic messages can be displayed.

Pressing program key 1 displays the current error code. A key explaining the error codes can be found inside the front cover of the appliance.

The arrow up and arrow down keys can be used to view the last ten error codes displayed in chronological order from “0” to “9” alongside the corresponding error code with “0” being the most recent.

### **“LL”: Lock level**

The operating mode of the appliance can be restricted.

#### **Setting options:**

“0” no restriction (factory setting)

“1” disables “Reset to factory setting”.  
Parameters can be viewed but not modified in service menu

“2” as “1”, additionally service menu cannot be displayed

“3” as “2”, additionally program 1 and 2 set temperature values cannot be changed

“4” as “3”, additionally set temperature value on appliance cannot be changed

**Note:** when lock level 1, 2, 3 or 4 is selected the system parameters cannot be modified in the service menu.

In order to modify system parameters it is necessary to remove the jumper from the main PCB as described under “Deactivation of the Lock level”.

# Operation

The appliance switches on automatically when the hot water tap is opened and switches off automatically when the hot water tap is closed.

## Temperature setting

The required outlet temperature can be adjusted gradually to a higher or lower value with the up arrow and down arrow keys.

Pressing a key once briefly changes the temperature by 0.5°C between 35°C and 42°C and by 1°C outside that range.

Pressing a key for a longer time changes the temperature continuously.

The required outlet temperature can be adjusted between 30°C and 55°C.

Note: reducing the temperature below 30°C displays “-” and the heating function will not operate.

## Program buttons

The two program keys allow a preset temperature to be selected quickly.

The factory setting is 35°C for program 1 and 48°C for program 2.

The preset temperature can be changed to the current temperature setting by prolonged pressing of the program key. The display changes from “P1” or “P2” to the new temperature value which becomes available each time the corresponding program key is pressed.

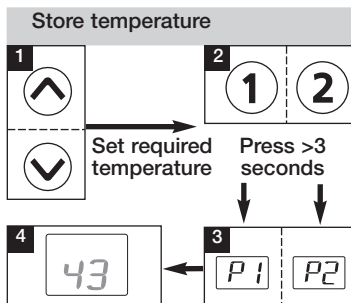
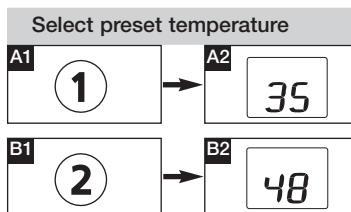
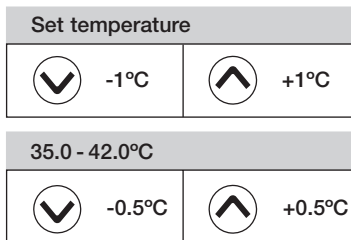

### Temperature limitation

Units are supplied with the temperature limitation function deactivated.

To activate, select the limit temperature then press the program 1 and up arrow function keys simultaneously for at least 3 seconds.

“HI” is displayed briefly to confirm activation.

To deactivate, press the program 1 and down arrow function keys simultaneously for at least 3 seconds.

“- -” is displayed briefly to confirm deactivation.

Note: Programmed temperature settings may need to be reset after deactivating temperature limitation.

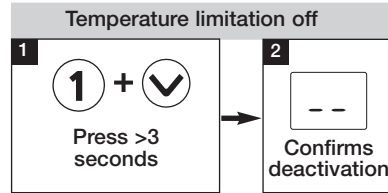
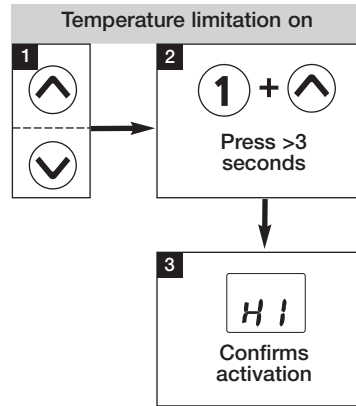

### Reset to factory setting

To reset to factory settings press the up arrow and down arrow function keys simultaneously.

The display will count backwards from “10” to “00” in one second intervals.

The appliance is reset when the counter reaches “00”.

Releasing the function keys earlier will cancel the process.

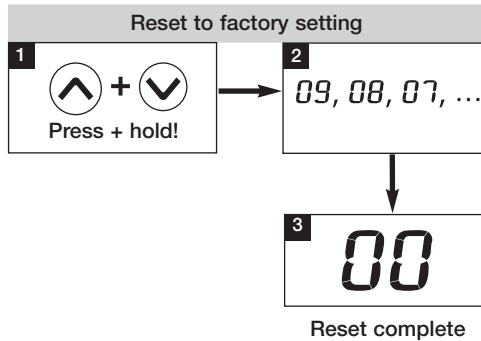



### Energy saving

Set the required hot water temperature on the appliance.

If the water is too hot reduce the temperature on the appliance instead of mixing with cold water.

Adding cold water wastes valuable energy that has been used producing excessively hot water.

Also, any cold water added is not controlled by the electronic circuitry meaning that precise temperature control can no longer be guaranteed when supplying more than one outlet.

### Power limit

If the maximum power available from the appliance is insufficient to heat the volume of hot water being drawn off to the required temperature this will be indicated by "MAX" on the display.

Reducing the flow rate will enable the required temperature to be delivered.

### Operation with solar systems

The appliance is suitable for use with solar heating systems providing appropriate controls are in place to ensure that the temperature of the water entering the unit does not exceed 70°C.

If the inlet temperature exceeds the set point, the "SUN" symbol on the display indicates that the heating power is switched off.

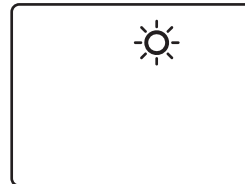

## ***Cleaning and maintenance***

N.B. Maintenance work must only be carried out by a competent person familiar with instantaneous water heaters.

Plastic surfaces and sanitary fittings should only be wiped with a damp cloth. Never use abrasive cleaning agents or solvents.

Outlet fittings (tap nozzles and shower heads) should be unscrewed and cleaned at regular intervals.

The electrical and plumbing components should be inspected regularly by a competent person to ensure proper functioning and operational safety. Water quality should be considered when determining the frequency of inspection.

Each time the appliance is emptied (e.g. due to work on the plumbing system, if there is a risk of freezing or in case of maintenance), the appliance must be vented by opening and closing the hot water tap until all air has been eliminated from the water heater and no more air emerges before re-connecting to the electrical supply.

## ***Fault finding***

**Repairs should only be carried out by competent persons familiar with electric instantaneous water heaters.**

All service work should be performed by an authorized Zip service engineer – for details of the full range of services available call Zip Service on 0845 602 4533.

When calling for service, please always specify the appliance model and serial number.

The following table will be helpful in determining the causes of some common problems and their solutions.

<b>Problem</b>	<b>Cause</b>	<b>Solution</b>
Water stays cold	Circuit breaker tripped	Reset circuit breaker
	STDB tripped	Contact Zip Service to reset STDB
Display flashes error message 'Er'	Control system has switched off	Switch power supply off and on. If 'Er' still flashes contact Zip Service
Poor hot water flow rate	Outlet fitting dirty or calcified	Clean shower head or tap nozzle
	Fine filter dirty or calcified	Contact Zip Service to clean fine filter
Selected temperature not achieved, "MAX" lights up	Excessive water flow rate	Reduce water flow rate at the outlet
Selected temperature not achieved, "MAX" does not light	Cold water has been added at the outlet	Set for required temperature and tap hot water only
Symbol "SUN" flashes	Inlet temperature exceeding set point	Reduce inlet temperature
Water heats but display fails to operate	Display lead plug not properly connected	Contact Zip Service to connect display lead correctly